



PQM II

POWER QUALITY METER

Power Quality and Energy Cost Management

KEY BENEFITS

- Power quality metering with waveform capture and historical data logging
- Easy to program and use with keypad and large illuminated 40 character display
- Multiple communication ports for integration with DCS and SCADA systems
- Supports DNP 3.0 and Modbus protocols
- Digital and analog I/Os for control and alarms
- Voltage disturbance recording capability for electrical sag and swell events.

APPLICATIONS

- Metering of distribution feeders, transformers, generators, capacitor banks and motors
- Commercial, industrial, utility
- Medium and low voltage systems
- Flexible control for demand load shedding, power factor, etc.

FEATURES

Monitoring and Metering

- Ia Ib Ic In
- Va Vb Vc Vab Vbc Vca
- V I unbalance
- True PF crest and K factor
- Hz W var VA
- Wh varh VAh W cost
- Demand: A W var VA
- Harmonic analysis through 63rd with THD and TIF
- Event recorder - 150 events
- Waveform capture
- Data logger -98,000 events
- Voltage Disturbance Recorder (VDR) -500 events

Communications

- Front RS232 serial port (1,200 to 19,200 bps)
- Two rear RS485 serial ports with ModBus and DNP 3.0 protocol
- Ethernet connectivity provided by MultiNet
- EnerVista™ software is provided for setup and monitoring functions
- External dial-in modem capabilities

Protection & Control

- Load shedding
- Power factor control
- Pulse input totalizing

Introduction

GE Multilin has set a new standard in metering technology with the introduction of the PQM II. This meter, designed on the latest industry specifications, provides accurate and reliable three-phase power metering with an optional Ethernet and fiber communications module in a small and modern package. The PQM II can be used for a variety of applications including metering of distribution feeders, transformers, generators and motors.

Robust Metering and Power Quality Capabilities in One Package

The PQM II is an ideal choice when continuous monitoring of a three phase system is required. It provides metering for current, voltage, real and reactive power, energy use, cost of power, power factor and frequency. Waveform capture and Voltage Disturbance Recorder continuously monitors power quality. Programmable setpoints and 4 assignable output relays allow control functions to be added for specific applications.

Communications Made Easy

Integrate process, instrumentation and electrical requirements in a plant automation system by connecting PQM II meters to a DCS or SCADA system. Meter provides multiple communication ports that can provide data simultaneously to multiple masters such as SCADA, DCS, BMS etc. Meter supports both ModBus and DNP 3.0 protocol. A computer running EnerVista™ software can change system setpoints, monitor values, status and alarms. Continuous monitoring minimizes process downtime by immediately identifying potential problems due to faults or changes.

Industry leading software makes setup simple

The PQM II comes complete with EnerVista™ GE Multilin's suite of software tools for managing the entire lifecycle implementation of the PQM II. EnerVista™ contains all of the tools for setting up and configuring your PQM II in minutes via RS232, RS485, external modem or Ethernet LAN.

Ethernet capability

With the optional Multinet module, users can add Ethernet capability to their meter. Multinet is an Ethernet communications module that allows connection of up to 30 ModBus devices, providing ModBus TCP/IP communications for these devices over Ethernet. This allows connection to Fiber Optic LAN and WAN systems for remote access to data on the PQM II.

Standard Features

The PQM II provides continuous monitoring of a three-phase system. It provides metering of current, voltage, real and reactive power, energy use, cost of power, power factor and frequency. Ethernet communications are available through the optional Multinet module.

Metering

PQM II is a true RMS meter with 0.2% accuracy for voltage and currents. The PQM II provides advanced features for monitoring and metering which include:

- Ia Ib Ic In
- Va Vb Vc Vab Vbc Vca
- V I unbalance
- True PF crest and K factor

- Hz W var VA
- Wh varh VAh W cost
- Demand: A W var VA

Keypad and illuminated 40 character display provides local setpoint settings and monitoring of values and status.

Mounting Versatility

PQM II panel mount with display, offers an easy local interface. Standard models have RS485 communications for programming and monitoring. Users can replace expensive additional devices by adding the CONTROL, TRANSDUCER and POWER analysis options to the PQM II as required.

Alarms

Any of the assignable outputs may be used to trigger an alarm for specific applications. Simple alarm messages provide easy notification.

CONDITION	APPLICATION
overcurrent	motors/transformers
undercurrent	pumps/compressors
neutral current	leakage/unbalance
current unbalance	motors
overvoltage	equipment protection
undervoltage	motors/load transfer
phase sequence	pumps/equipment
overfrequency	generators
underfrequency	load shedding
power factor	capacitor banks
switch input	process control



Connect up to 32 ModBus devices to your Ethernet network

Communications

Integrate process, instrumentation and electrical requirements in a plant automation system by connecting PQM II meters to a DCS or SCADA system. Initially PQM II meters can be used as stand-alone units. Open architecture allows connection to other ModBus® compatible devices on the same communication link. At a later stage PQM II can be integrated in a complete plant wide system for overall process monitoring and control. The standard PQM II comes complete with a rear RS485 and front RS232 port. RS232 port can be used for data collection, printing reports or problem analysis without disturbing the main RS485 communication interface at rear. The standard meter provides:

- RS485 ModBus® 1,200 to 19,200-bps
- DNP 3.0 Level 2 Protocol
- Mini RTU SCADA system component
- Measure actual values
- Read status
- Issue control commands
- Load all setpoints from a file
- Change individual setpoints

A computer running EnerVista™ software can change system setpoints, monitor values, status and alarms. Continuous monitoring minimizes process downtime by immediately identifying potential problems due to faults or changes.

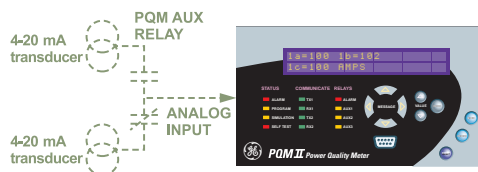

Connect two 4 to 20 mA transducers for process variable measurement and control.

Future Expansion

The PQM II uses non-volatile flash memory for firmware storage. This allows future product upgrades to be loaded via the serial port. Upgrades can also be downloaded from the GE Multilin website.

Options

There are a variety of options available to the user, allowing a range of custom configurations:

Transducer

Four Analog Outputs: Four isolated analog outputs can be used to replace eight analog transducers. Output signals can be selected from any of the measured parameters for direct interface to a PLC or other devices.

Analog Input: PQM II meter can accept two analog inputs from external devices. Meter can be programmed to activate a control relay based on analog input from transducers (temperature, level etc.)

Communications

Second Rear Comm Port: An additional rear RS485 comm port is provided for simultaneous monitoring by process, instrument, electrical or maintenance personnel.

Control

Three output relays and four inputs allow measured parameters from the standard PQM II to be combined with setpoints and I/Os for control applications. With the control option, three output relays and four switch inputs are added along with programmable setpoints to make a mini RTU. Output relays can also be controlled via the communication port or assigned to different setpoints for custom programming to accommodate many applications such as:

- Undercurrent alarm for pumps
- Over and undervoltage for generators
- Unbalance alarm for rotating machines
- Dual level power factor for capacitor bank switching
- Underfrequency/demand output for load shedding resulting in power cost savings
- kWh, kvarh and kVAh pulse output for PLC interface

Power Analysis

Data Logger (Trending): Trending is useful as a troubleshooting aid when a problem is detected. Measured values can be selected and plotted with a programmable sampling rate to suit the time interval of interest. The generated chart recorder screen can be printed or

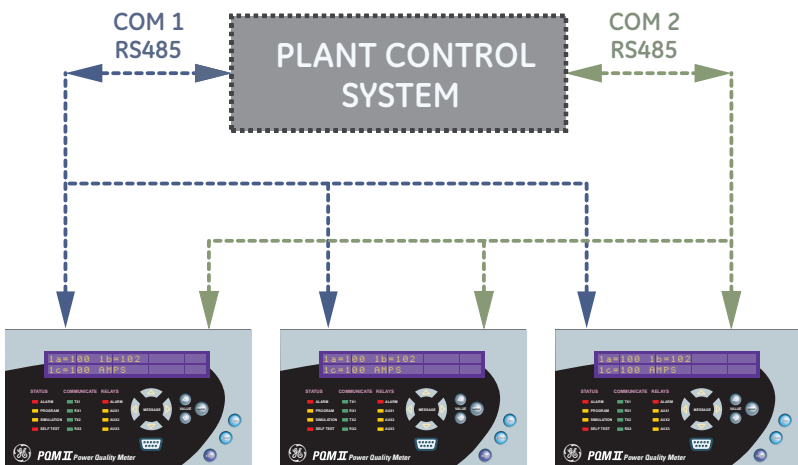

Redundancy in high security systems is provided by the 2nd RS485 comm port.

Digital Metering

exported to other programs for report writing.

Harmonic Analysis: Non linear loads such as variable speed drives, computers and electronic ballasts can cause harmonics which may lead to problems such as nuisance breaker tripping, telephone interference, transformer, capacitor or motor overheating. Harmonic analysis can be used for fault diagnosis such as detecting undersized neutral wiring, need for a harmonic rated transformer, or effectiveness of harmonic filters. Details of the harmonic spectrum are useful and available with the power analysis option.

Voltage Disturbance Recorder (VDR)

The Voltage Disturbance Recorder (VDR) function adds to the PQM II the ability to monitor and record Sag and Swell disturbances. It can record up to 500 sag/swell events for all voltages simultaneously.

Waveform Capture: Voltage and current waveforms can be captured and displayed on a PC using the EnerVista™ program supplied with the PQM II or using third party software. Distorted peaks or notches from SCR switching provide clues for taking corrective action.

Event Recorder: Alarms, setpoint triggers, input and output events can be stored in a 150 event record and time and date stamped by the internal clock. This is useful for diagnosing problems and system activity. Minimum and maximum values are also continuously updated and time stamped.

Trace Memory: The PQM II can be configured to record a maximum of 36 cycles of data on all voltage and current inputs based on overvoltage, undervoltage, overcurrent or switch input state change.

EnerVista™ Software

EnerVista™ Launchpad

EnerVista™ Launchpad is a powerful software package that provides users with all of the setup and support tools needed for configuring and maintaining GE Multilin Products. Launchpad allows configuration of devices in real-time by communicating using RS232, RS485, Ethernet, or modem connections.

The intuitive user interface makes it simple to enter setpoints, read metered values, monitor status and evaluate power quality. Powerful troubleshooting features make it easy to retrieve and view voltage & current waveshapes and harmonic analysis. This vital information can help provide early warning of problems and prevent equipment damage or nuisance breaker tripping.

EnerVista Launchpad PQM II Setup and Analysis

PQM II setup program contains many tools and reports that simplify device configuration and allows viewing of power system events.

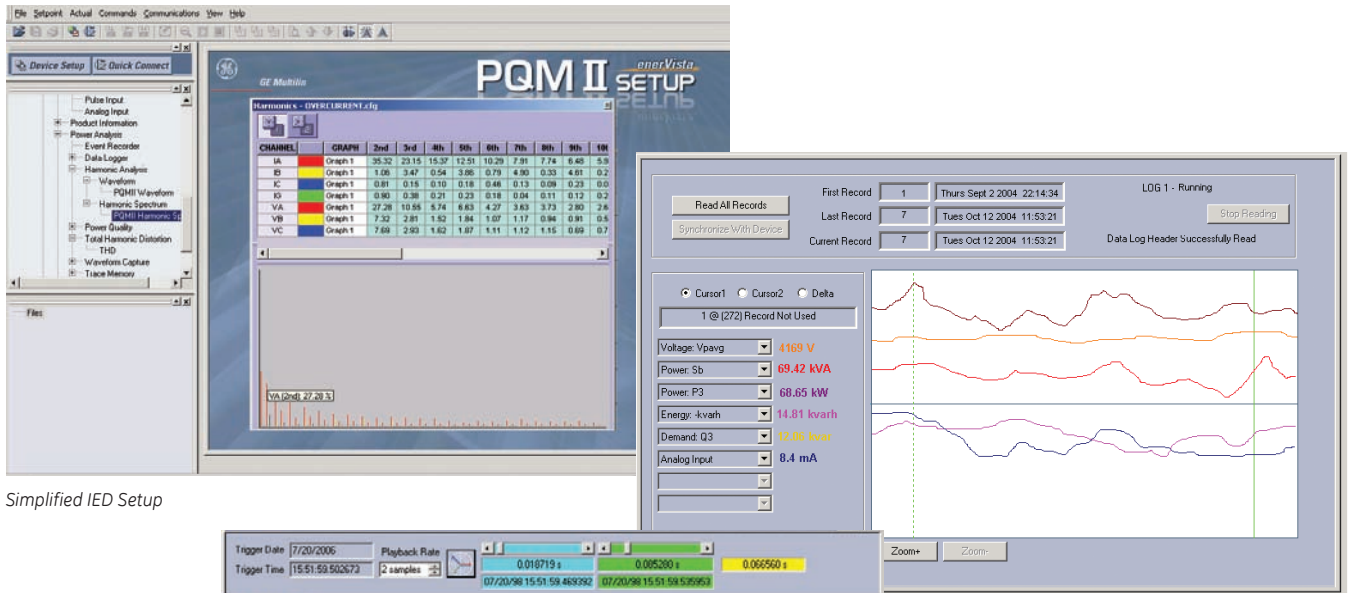

Simplified IED Setup

Record trends of measured parameters over time

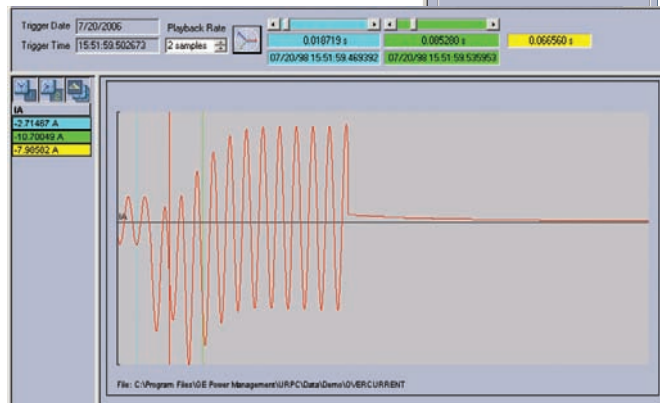

Voltage and current waveforms provide valuable insights into system problems

Included in Launchpad is a document archiving and management system that ensures critical documentation is up-to-date and available when needed by automatically checking for and downloading new versions of manuals, applications notes, specifications, and service bulletins.

Viewpoint Monitoring

Viewpoint Monitoring is a simple-to-use, full-featured monitoring and data recording software package for small systems. Viewpoint Monitoring provides a complete HMI package that instantly puts critical real-time device data on your PC through pre-configured graphical screens with the following functionality.

- Plug-&-Play Device Monitoring
- System Single-Line Monitoring & Control

- Annunciator Alarm Screens
- Trending Reports
- Automatic Event Retrieval
- Automatic Waveform Retrieval

EnerVista™ Integrator

EnerVista™ Integrator is a toolkit that allows seamless integration of GE Multilin devices into new or existing automation systems by sending GE device data to HMI, DCS, and SCADA systems. Included in EnerVista Integrator is:

- OPC/DDE Server
- GE Multilin Drivers
- Automatic Event Retrieval
- Automatic Waveform Retrieval

EnerVista Viewpoint Monitoring Plug-and-Play Screens

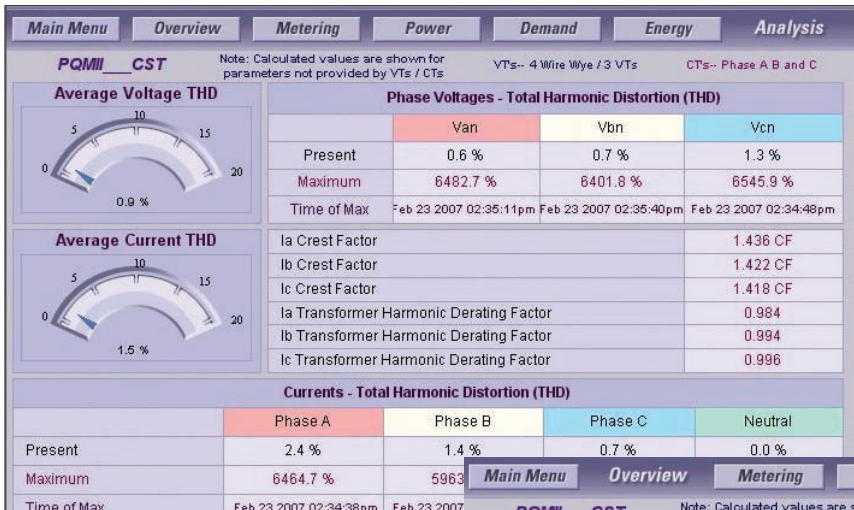

Viewpoint Monitoring PGM II analysis screen for detailed power quality information

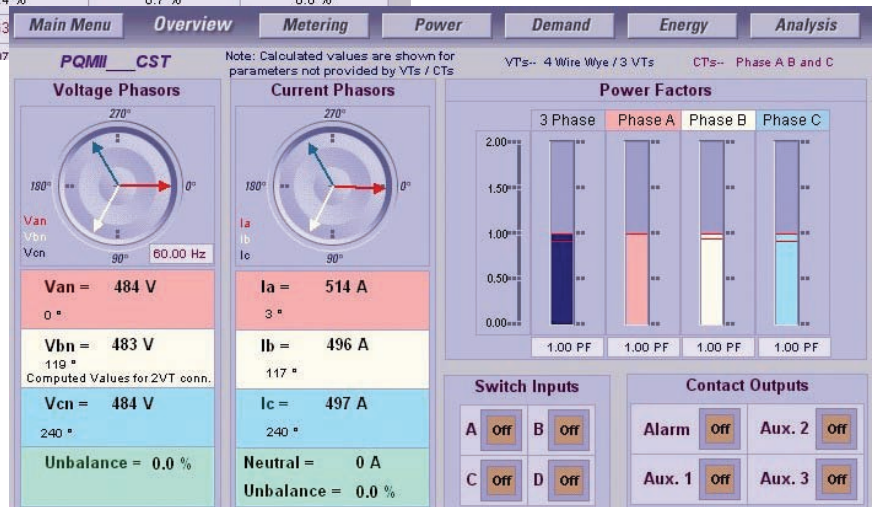

Viewpoint Monitoring PGM II real-time overview screen for detailed device status

Typical Wiring

Digital Metering

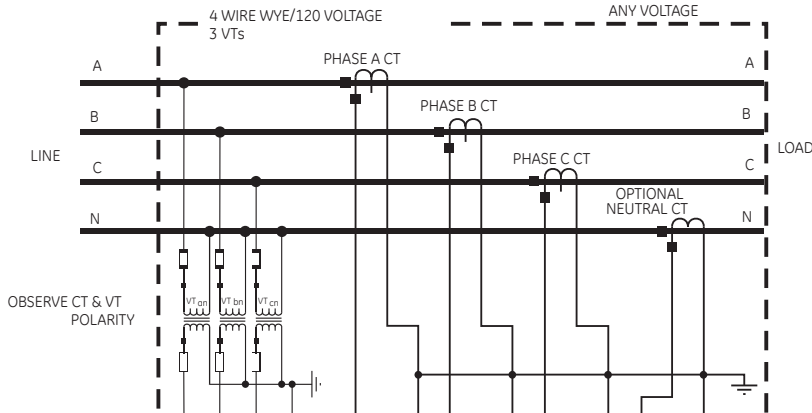
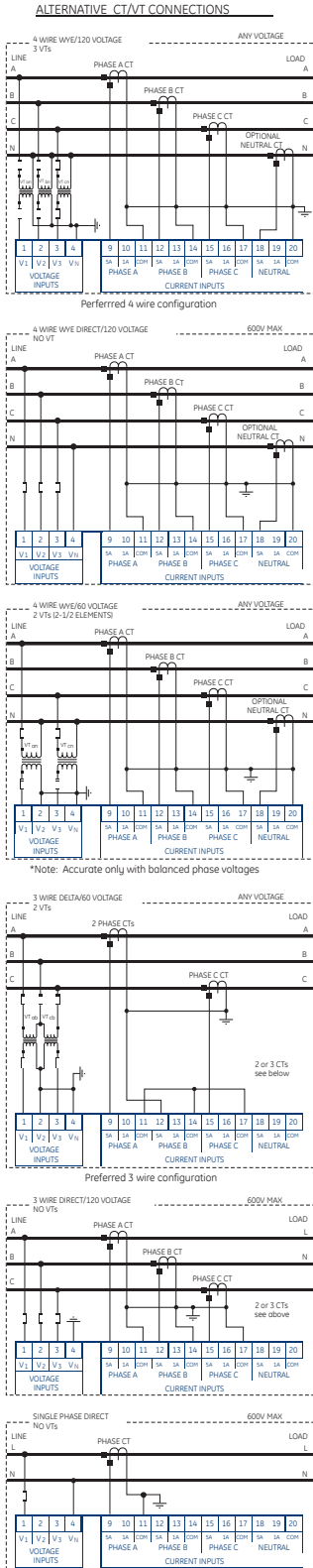

GE Multilin PQM II Power Quality Metering System

CONTROL POWER 90-300 VDC 70-265 VAC 50/60 Hz

USE HEAVY GAUGE WIRE SWITCHGEAR GROUND BUS

USE SHIELDED TWISTED PAIR WIRE

COM1 RS485 TO/FROM DEVICE

COM2 RS485 TO/FROM DEVICE

4-20mA TRANSDUCER

TO PLC OR SCADA SYSTEM

COM3 RS232 (FRONT)

RS232 INTERFACE

PERSONAL COMPUTER ENERVISTA

1	2	3	4	9	10	11	12	13	14	15	16	17	18	19	20				
V ₁	V ₂	V ₃	V _N	5A	1A	COM	5A	1A	COM	5A	1A	COM	5A	1A	COM				
VOLTAGE INPUTS				CURRENT INPUTS															
				PHASE A				PHASE B				PHASE C				NEUTRAL			

8	7	6	5
CONTROL POWER	SAFETY GROUND	FILTER GROUND	

45	NO	ALARM
44	COM	
43	NC	AUX1
42	NO	
41	COM	AUX2
40	NC	
39	NO	AUX3
38	COM	
37	NC	PROGRAMMABLE SWITCH INPUTS
36	NO	
35	COM	SW1
34	NC	
32	SW2	SW2
31	SW3	
30	SW3	SW3
29	SW4	
33	+24VDC	

OUTPUT RELAYS

ANALOG IN

ANALOG OUT 4-20mA

DRY CONTACT SWITCH INPUTS

- NOTES:
- Relay contact state shown with control power not applied.

CAUTION: USE HIRC FUSES FOR VT PRIMARY TO ENSURE ADEQUATE INTERRUPTING CAPACITY.

- Transducer Option
- Control Option

Technical Specifications

MONITORING

UNDERVOLTAGE MONITORING

Required voltage: 20 V applied
Pickup level: 0.50 - 0.99 in steps of 0.01 x VT
Dropout level: 103% of pickup
Time delay: 0.5 - 600.0 in steps of 0.5 sec
Phases: Any one/any two/all three (programmable) phases have to go below pickup to operate
Level accuracy: Per voltage input
Timing accuracy: -0/+1 sec

OVERVOLTAGE MONITORING

Pickup level: 1.01 - 1.25 in steps of 0.01 x VT
Dropout level: 97% of pickup
Time delay: 0.5 - 600.0 in steps of 0.5 sec
Phases: Any one/any two/all three (programmable) phases have to exceed pickup to operate
Level accuracy: Per voltage input
Timing accuracy: -0/+1 sec

UNDERFREQUENCY MONITORING

Required voltage: 20 V applied
Pickup level: 20 - 70.00 in steps of 0.01 Hz
Dropout level: Pickup +0.03 Hz
Time delay: 0.1 - 10.0 in steps of 0.1 sec
Level accuracy: ±0.02 Hz
Timing accuracy: ±3 cycles

OVERFREQUENCY MONITORING

Required voltage: 20 V applied
Pickup level: 20 - 70.00 in steps of 0.01 Hz
Dropout level: Pickup -0.03 Hz
Time delay: 0.1 - 10.0 in steps of 0.1 sec
Level accuracy: ±0.02 Hz
Timing accuracy: ±3 cycles

POWER FACTOR MONITORING

Required voltage: 20 V applied
Pickup level: 0.50 lag - 0.50 lead in steps of 0.01
Dropout level: 0.50 lag - 0.50 lead in steps of 0.01
Time delay: 0.5 - 600.0 in steps of 0.5 sec
Timing accuracy: -0/+1 sec

SAMPLING MODES

	SAMPLES/ CYCLE	INPUTS SAMPLED AT A TIME	DURATION (CYCLES)
Metered values	64	ALL	2
Trace memory	16	ALL	continuous
Harmonic spectrum	256	1	1

DEMAND MONITORING

Measured values: Phase A/B/C/N current (A)
 3f real power (kW)
 3f reactive power (kvar)
 3f apparent power (kVA)
Measurement type: Thermal exponential
 90% response time (programmable):
 5 - 60 min, steps of 1 min
 Block interval/rolling demand time in interval (programmable): 5 - 60 min, steps of 1 min
Pickup level:
 A: 10 - 7,500 in steps of 1
 kW: 0.1 - 6,500.0 in steps of 0.1
 kvar: 0.1 - 6,500.0 in steps of 0.1
 kVA: 0.1 - 6,500.0 in steps of 0.1

METERING

MEASURED VALUES

PARAMETER	ACCURACY (% of full scale)	RESOLUTION	RANGE
Voltage	±0.2%	1 VOLT	20% of VT - 100% of VT
Current	±0.2%	1 A	1% of CT - 150% of CT
Voltage unbalance	±1%	0.1%	0 - 100.0%
Current unbalance	±1%	0.1%	0 - 100.0%
kW	±0.4%	0.01 kW	0 - 999,999.99 kW
kvar	±0.4%	0.01 kvar	0 - 999,999.99 kvar
kVA	±0.4%	0.01 kVA	0 - 999,999.99 kVA
kWh	±0.4%	1 kWh	2 ³² kWh
kvarh	±0.4%	1 kvarh	2 ³² kvarh
kVAh	±0.4%	1 kVAh	2 ³² kVAh
Power factor	1%	0.01	±0.0 - 1.0
Frequency	0.02 Hz	0.01 Hz	20.00 - 70.00 Hz
kw demand	±0.4%	0.1 kw	999,999.99 kw
kvar demand	±0.4%	0.1 kvar	999,999.99 kvar
kva demand	±0.4%	0.1 kva	999,999.99 kva
Amps demand	±0.2%	1 A	0 - 7,500 A
Amps THD	±2.0%	0.1%	0.0 - 100.0%
Volts THD	±2.0%	0.1%	0.0 - 100.0%
Crest factor	±0.4%	-	1 - 9.99

INPUTS

AC CURRENT

Conversion: True RMS, 64 samples/cycle
CT input: 1 A and 5 A secondary
Burden: 0.2 VA
Overload: 20 x CT for 1 sec
 100 x CT for 0.2 sec
 150% of CT
Full scale: up to 32nd harmonic
Frequency: ±0.2% of full scale, true RMS
Accuracy:

AC VOLTAGE

Conversion: True RMS, 64 samples/cycle
VT pri/sec: Direct or 120 - 72,000 : 69 - 240
Input range: 20 - 600 VAC
Full scale: 150/600 VAC autoscaled
Burden: <0.1 VA
Frequency: up to 32nd harmonic
Accuracy: ±0.2% of full scale, true RMS

SWITCH INPUTS

Type: Dry contact
Resistance: 1,000 Ω max ON resistance
Voltage: 24 VDC @ 2 mA
Duration: 100 ms minimum

ANALOG INPUT

Range: 4 - 20 mA
Accuracy: ±1% of full scale
Relay output: Programmable 4 - 20 mA
Internal burden resistance: 250 Ω

PULSE INPUT

Max inputs: 4
Min pulse width: 150 ms
Min off time: 200 ms

COMMUNICATIONS

COM1/COM2 type: RS485 2-wire, half duplex, isolated
COM3 type: RS232, 9PIN
Baud rate: 1,200 - 19,200 bps
Protocol: ModBus[®] RTU and DNP 3.0 level 2
Functions: Read/write setpoints
 Read actual values
 Execute commands

POWER SUPPLY

CONTROL POWER

Input: 90 - 300 VDC
 70 - 265 VAC 50/60 Hz
Power: 10 VA nominal, 20 VA maximum
Holdup: 100 ms typical @ 120 VAC/VDC

ENVIRONMENTAL

Operating Temperature: -10C to +60C
Humidity: operating up to 95% (non condensing) @ 55C
Pollution Degree: 2
Ingress Protection: IP40 (front), IP20 (back)

PACKAGING

Shipping box: 8 1/2" L x 6" H x 6" D
 (215 mm x 152 mm x 152 mm)
 5 lbs (2.3 kg)
Ship weight: 5 lbs (2.3 kg)
NOTE: LCD contrast impaired below -20° C

OUTPUTS

ANALOG OUTPUTS

Accuracy: ±1% of full scale reading

	OUTPUT	
	0 - 1 mA (T1 Option)	4 - 20 mA (T20 Option)
Max load	2400 Ω	600 Ω
Max output	1.1 mA	21 mA

Isolation: +/- 36 VDC isolated, active source

OUTPUT RELAYS

Voltage	Make/Carry Continuous	Make/Carry 0.2 SEC	Break
30 VDC	5	30	5
Resistive 125 VDC	5	30	0.5
250 VDC	5	30	0.3
30 VDC	5	30	5
Inductive 125 VDC	5	30	0.25
(Vr = 7ms) 250 VDC	5	30	0.15
120 VAC	5	30	5
Resistive 250 VAC	5	30	5
Inductive 120 VAC	5	30	5
PF = 0.4 250 VAC	5	30	5
Configuration	FORM C NO/NC		
Contact material	SILVER ALLOY		

PULSE OUTPUT

Parameters: +ve kWh, -ve kWh, +ve kvarh, -ve kvarh, kVAh
Interval: 1 - 65000 in steps of 1
Pulse width: 100 - 2000 ms in steps of 10 ms
Min pulse interval: 500 ms

TYPE TESTS

Dielectric voltage withstand: EN60255-5
Impulse voltage withstand: EN60255-5
Insulation resistance: EN60255-5
Damped Oscillator: IEC61000-4-18 / IEC60255-22-1
Electrostatic Discharge: EN61000-4-2 / IEC60255-22-2
RF immunity: EN61000-4-3 / IEC60255-22-3
Fast Transient Disturbance: EN61000-4-4 / IEC60255-22-4
Surge Immunity: EN61000-4-5 / IEC60255-22-5
Conducted RF Immunity: EN61000-4-6 / IEC60255-22-6
Radiated & Conducted Emissions: CISPR11 / CISPR22 / IEC60255-25
Sinusoidal Vibration: IEC60255-21-1
Shock & Bump: IEC60255-21-2
Power magnetic Immunity: IEC61000-4-8
Pulse Magnetic Immunity: IEC61000-4-9
Voltage Dip & interruption: IEC61000-4-11
Ingress Protection: IEC60529
Environmental (Cold): IEC60068-2-1
Environmental (Dry heat): IEC60068-2-2
Relative Humidity Cyclic: IEC60068-2-30
EFT: IEC61000-4-11
 IEEC / ANSI C37.90.1

APPROVALS

ISO: Manufactured to an ISO9001 registered program
cULus e83849 NKCR/7: UL508, UL1053, C22.2 No 14
CE: EN60255-5, EN61000-6-2

PQM II Dimensions

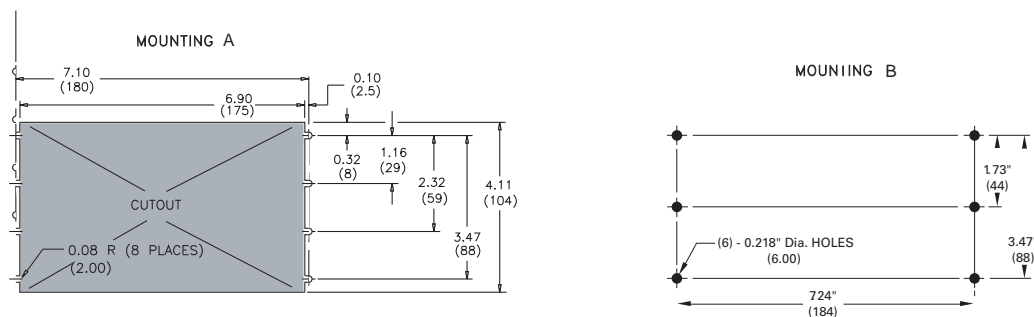
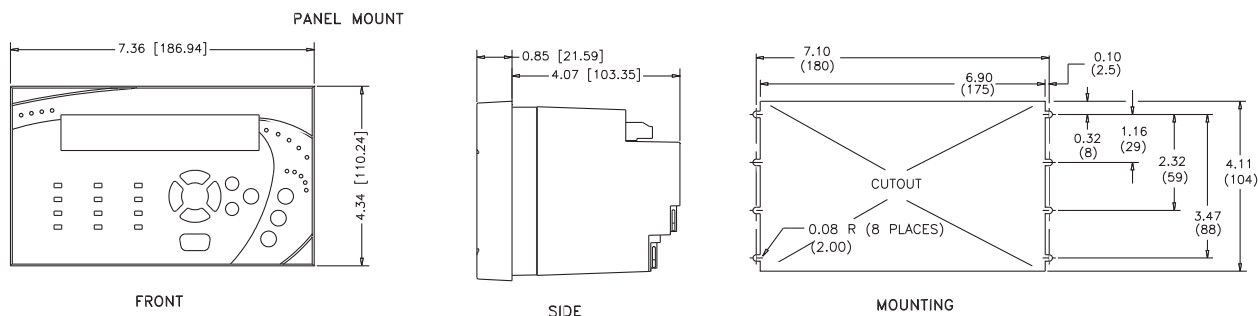

Ordering

PQM II	*	*	*	Description
PQM II				Basic unit with display, all current/voltage/power measurements, 1-RS485 comm port, 1 RS232 comm port
	T20			Transducer option; 4 isolated analog outputs 0 – 20 mA and 4 – 20 mA, assignable to all measured parameters, 4 – 20 mA analog input, 2nd RS485 comm port
	T1			Transducer option; 4 isolated analog outputs 0 – 1 mA, assignable to all measured parameters, 4 – 20 mA analog input, 2nd RS485 comm port
		C		Control option; 3 additional programmable output relays (total of 4), 4-programmable switch inputs
			A	Power analysis option; harmonic analysis, triggered trace memory waveform capture, event record, data logger, voltage disturbance recorder (VDR)

Modifications:

MOD 501:	20 – 60 VDC/20 – 48 VAC control power
MOD 502:	Tropicalization
MOD 504:	Removable terminal blocks
MOD 507:	-40 to +60° C temperature operation

Control Power:

90 – 300 VDC/70 – 265 VAC standard
20 – 60 VDC/20 – 48 VAC (MOD 501)

Accessories for the PQM II:

• Multilink Ethernet Switch	ML1600-HI-A2-A2
• Multinet	Multinet-FE
• Viewpoint Monitoring	VP-1

Visit www.GEMultilin.com/PQM II to:



- View Guideform Specifications
- Download the instruction manual
- Review applications notes and support documents
- Buy a PQM II online